

ITEM: 3" BASEBOARD

QTY: 1

3" BASEBOARD

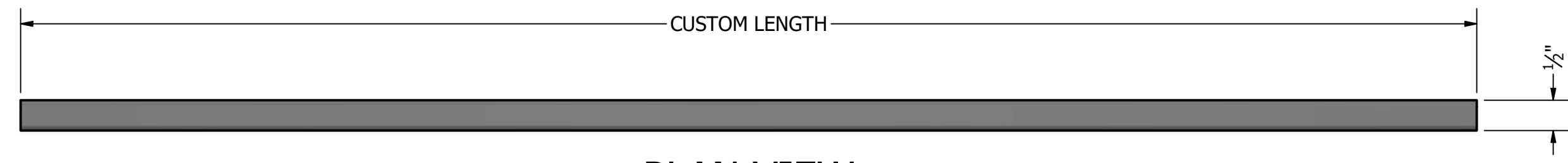

PLAN VIEW
SCALE 6" = 12"

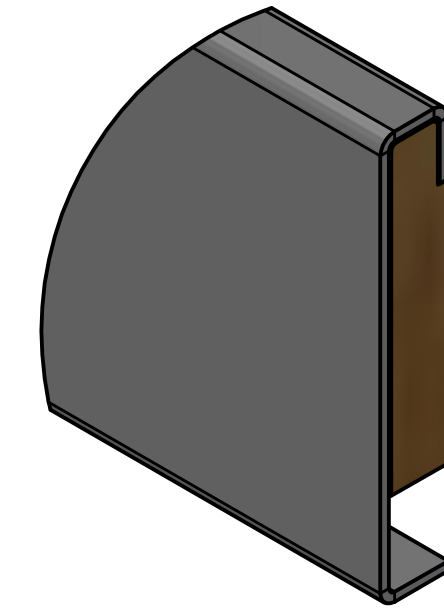

DETAIL B
NO END CAP
SCALE 12" = 1'-0"

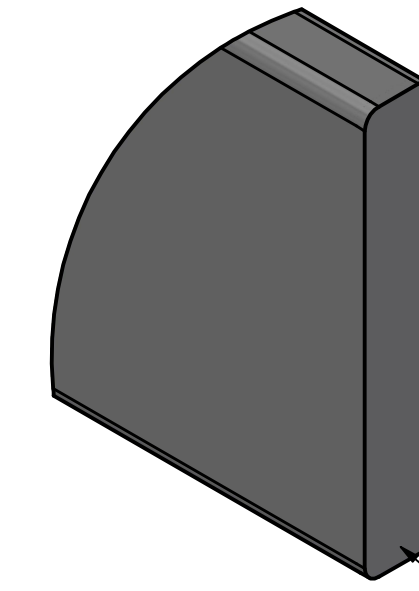

DETAIL B
WITH END CAP
SCALE 12" = 1'-0"

END CAPS AVAILABLE PER CUSTOMER SELECTION

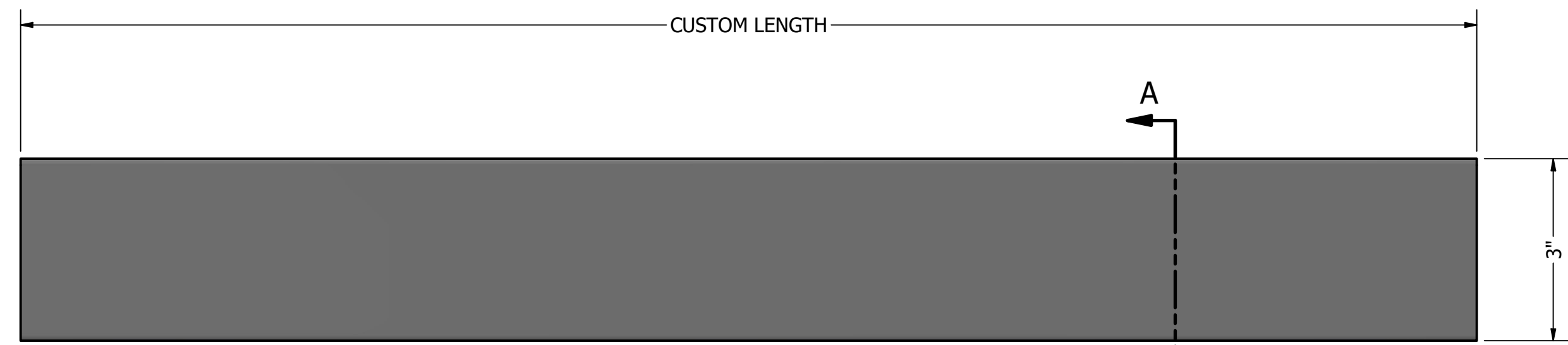
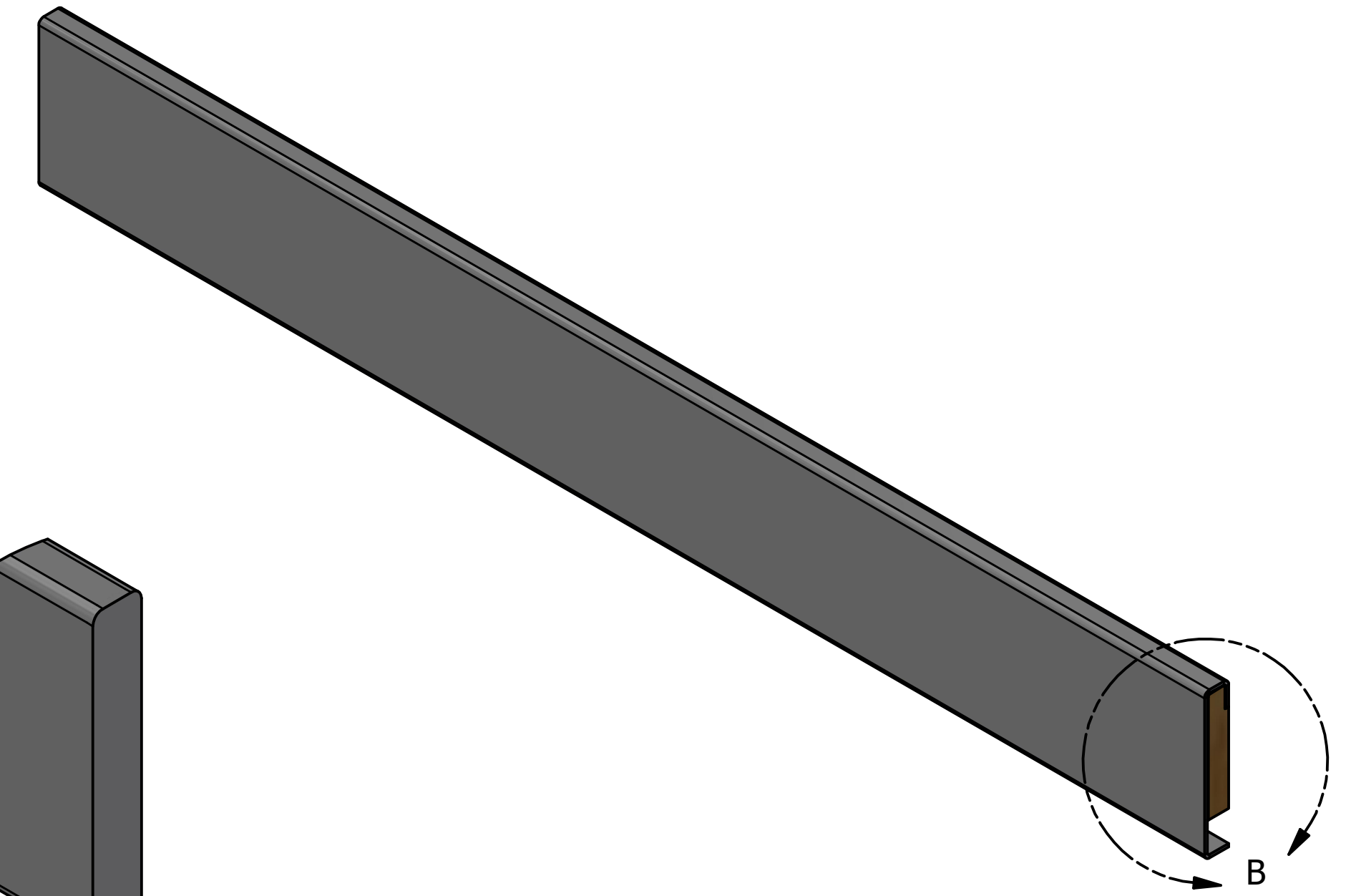

FRONT ELEVATION
SCALE 6" = 12"

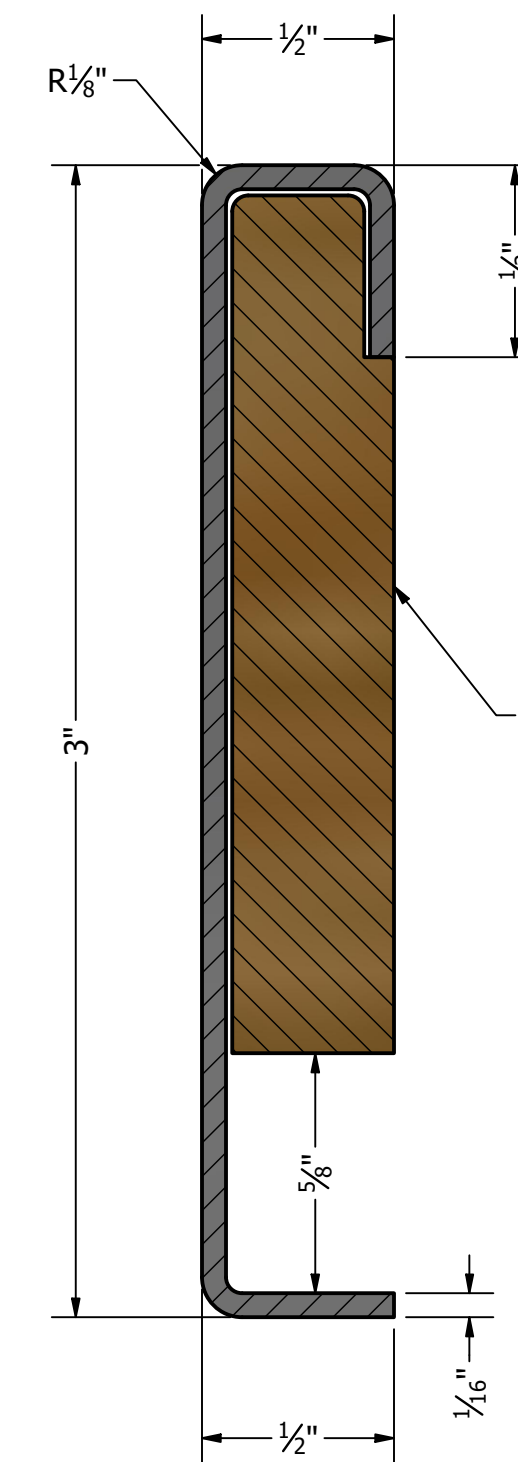

SECTION A-A
SCALE 2 : 1

MDF WALL CLEATS
(2) PROVIDED PER LENGTH, PLUS
ADDITIONAL SO THAT CLEAT SPACING
DOES NOT EXCEED 16" O.C.

THESE PLANS AND THE DESIGNS CONTAINED HEREIN ARE THE PROPERTY OF GREAT LAKES STAINLESS, INC., AND MAY NOT BE REPRODUCED OR USED BY ANYONE, EITHER ALL OR IN PART, WITHOUT FIRST SECURING OUR WRITTEN PERMISSION.

DRAWN RICK		1305 STEPKE COURT TRAVERSE CITY, MI. 49685 (888) 547-5282
PROJECT MANAGER:		JOB NAME : 3" BASEBOARD
REVISIONS:	CUSTOMER :	ITEM#:
TOLERANCES UNLESS OTHERWISE STATED: XXX ±.0002 XXX ±.005 XX ±.010 FRACTIONAL ±1/8" ANGLES ±1/2°	SIZE D	3IN BASEBOARD
	DATE: 10/1/2021	SHEET 1 OF 1